



SPECIFICATION SPECIFICATION

2.4-GHz *Bluetooth*[®] low energy System-on-Module



Bluetooth[®]

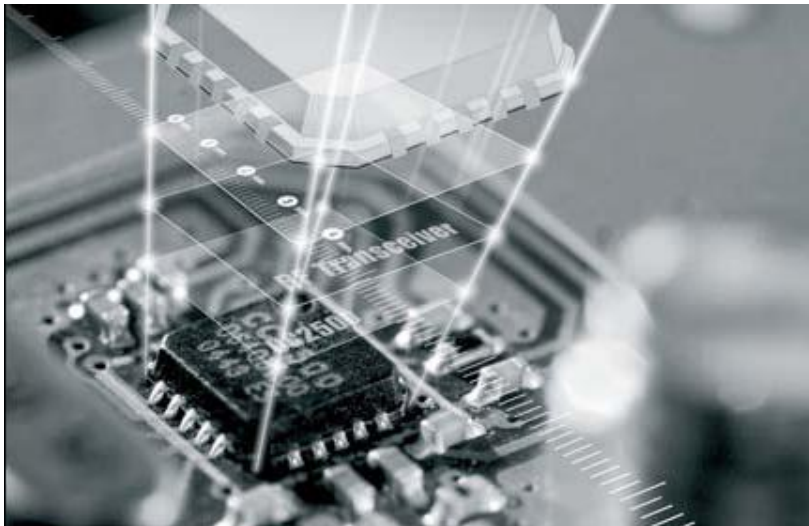

Model : **2.4GHz RF Module**
Part No : TM41B1412-xxxx
Version : V3.4
Date : 2016.04.23

■ Applications

- *2.4-GHz Bluetooth low energy Systems*
- *Proprietary 2.4-GHz Systems*
- *Human-Interface Devices (Keyboard, Mouse ,Remote Control)*
- *Sports and Leisure Equipment*
- *Mobile Phone Accessories*
- *Consumer Electronics*

■ Selection Guide

Denomination : 2.4GHz Bluetooth RF Module

Part No. : TM41B1412-SFxxx (with Shielding case)

128/256 KB in-system Programmable Flash

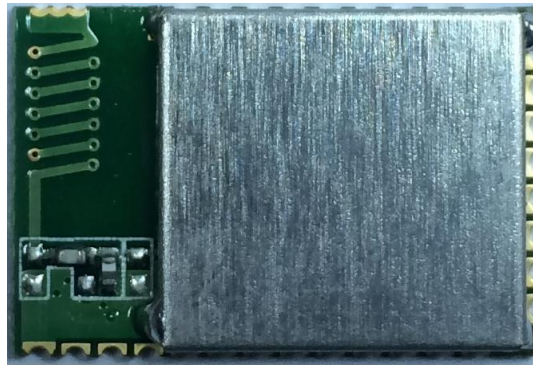

(TM41B1412-SFxxx)

TM41B1412-Fxxx (without Shielding case)

128/256 KB in-system Programmable Flash



(TM41B1412-Fxxx)

TM41B1412-Exxxx (External Antenna)

128/256 KB in-system Programmable Flash



(TM41B1412-EFxxx)

Absolute Maximum Ratings



Caution! ESD sensitive device. Precaution should be used when handling the device in order to prevent permanent damage.

		MIN	MAX	UNIT
Supply voltage	All supply pins must have the same voltage	-0.3	3.9	V
Voltage on any digital pin		-0.3	VDD + 0.3, ≤ 3.9	V
Input RF level			10	dBm
Storage temperature range		-40	125	°C
ESD ⁽²⁾	All pads, according to human-body model, JEDEC STD 22, method A114		2	kV
	According to charged-device model, JEDEC STD 22, method C101		750	V

Stresses beyond those listed under *Absolute Maximum Ratings* may cause permanent damage to the device. These are stress ratings only, and functional operation of the device at these or any other conditions beyond those indicated under *Recommended Operating Conditions* is not implied. Exposure to absolute-maximum-rated conditions for extended periods may affect device reliability.

CAUTION: ESD sensitive device. Precaution should be used when handling the device in order to prevent permanent damage.

Recommended Operation Condition

	MIN	MAX	UNIT
Operating ambient temperature range, T _A	-40	85	°C
Operating supply voltage	2	3.6	V

Electrical Specifications

● Current Consumption

T _A	PARAMETER	TEST CONDITIONS	MIN	TYP	MAX	UNIT
T _A	I _{core} Core current consumption	Power mode 1. Digital regulator on; 16-MHz RCOSC and 32-MHz crystal oscillator off; 32.768-kHz XOSC, POR, BOD and sleep timer active; RAM and register retention		235		μA
		Power mode 2. Digital regulator off; 16-MHz RCOSC and 32-MHz crystal oscillator off; 32.768-kHz XOSC, POR, and sleep timer active; RAM and register retention		0.9		
		Power mode 3. Digital regulator off; no clocks; POR active; RAM and register retention		0.4		
		Low MCU activity: 32-MHz XOSC running. No radio or peripherals. No flash access, no RAM access.		6.7		mA
T _A	I _{peri} Peripheral current consumption (Adds to core current I _{core} for each peripheral unit activated)	Timer 1. Timer running, 32-MHz XOSC used		90		μA
		Timer 2. Timer running, 32-MHz XOSC used		90		μA
		Timer 3. Timer running, 32-MHz XOSC used		60		μA
		Timer 4. Timer running, 32-MHz XOSC used		70		μA
		Sleep timer, including 32.753-kHz RCOSC		0.6		μA
		ADC, when converting		1.2		mA

PARAMETER	TEST CONDITIONS	MIN	TYP	MAX	UNIT
WAKE-UP AND TIMING					
Power mode 1 → Active	Digital regulator on, 16-MHz RCOSC and 32-MHz crystal oscillator off. Start-up of 16-MHz RCOSC		4		μs
Power mode 2 or 3 → Active	Digital regulator off, 16-MHz RCOSC and 32-MHz crystal oscillator off. Start-up of regulator and 16-MHz RCOSC		120		μs
Active → TX or RX	Crystal ESR = 16 Ω. Initially running on 16-MHz RCOSC, with 32-MHz XOSC OFF		500		μs
	With 32-MHz XOSC initially on		180		μs
RX/TX turnaround	Proprietary auto mode		130		μs
	BLE mode		150		
RADIO PART					
RF frequency range	Programmable in 1-MHz steps	2379		2496	MHz
Data rate and modulation format	2 Mbps, GFSK, 500-kHz deviation 2 Mbps, GFSK, 320-kHz deviation 1 Mbps, GFSK, 250-kHz deviation 1 Mbps, GFSK, 160-kHz deviation 500 kbps, MSK 250 kbps, GFSK, 160-kHz deviation 250 kbps, MSK				

RF Characteristics

1Mbps, GFSK, 250-KHz deviation, Bluetooth low energy mode and

1%BER

PARAMETER	TEST CONDITIONS	MIN	TYP	MAX	UNIT
1 Mbps, GFSK, 250-kHz Deviation, Bluetooth low energy Mode, 0.1% BER					
Receiver sensitivity ⁽³⁾⁽⁴⁾	High-gain mode		-94		dBm
	Standard mode		-88		
Saturation ⁽⁴⁾	BER < 0.1%		5		dBm
Co-channel rejection ⁽⁴⁾	Wanted signal -67 dBm		-6		dB
In-band blocking rejection ⁽⁴⁾	±1 MHz offset, 0.1% BER, wanted signal -67 dBm		-2		dB
	±2 MHz offset, 0.1% BER, wanted signal -67 dBm		26		
	±3 MHz offset, 0.1% BER, wanted signal -67 dBm		34		
	>6 MHz offset, 0.1% BER, wanted signal -67 dBm		33		
Out-of-band blocking rejection ⁽⁴⁾	Minimum interferer level < 2 GHz (Wanted signal -67 dBm)		-21		dBm
	Minimum interferer level [2 GHz, 3 GHz] (Wanted signal -67 dBm)		-25		
	Minimum interferer level > 3 GHz (Wanted signal -67 dBm)		-7		
Intermodulation ⁽⁴⁾	Minimum interferer level		-36		dBm
Frequency error tolerance ⁽⁵⁾	Including both initial tolerance and drift. Sensitivity better than -67dBm, 250 byte payload. BER 0.1%	-250		250	kHz
Symbol rate error tolerance ⁽⁵⁾	Maximum packet length. Sensitivity better than -67 dBm, 250 byte payload. BER 0.1%	-80		80	ppm

PARAMETER	TEST CONDITIONS	MIN	TYP	MAX	UNIT
Output power	Delivered to a single-ended 50-Ω load through a balun using maximum recommended output power setting		0		dBm
	Delivered to a single-ended 50-Ω load through a balun using minimum recommended output power setting		-23		
Programmable output power range	Delivered to a single-ended 50-Ω load through a balun using minimum recommended output power setting		23		dB

TM41B1412-Fxxx RF Module Pin Configuration

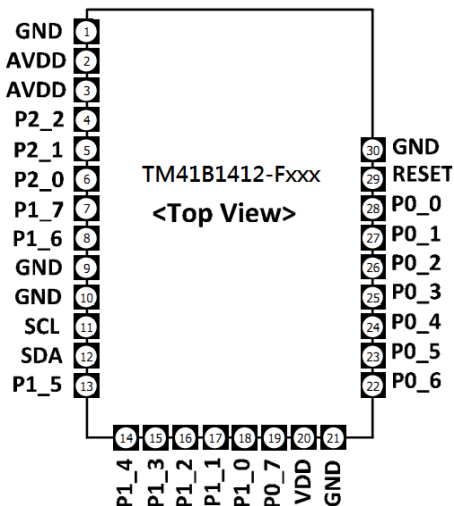

Pin #.	Pin Name	Pin Type	Description
1	GND	GND	Ground
2	AVDD	ANALOG POWER	2~3.6V power supply
3	AVDD	ANALOG POWER	2~3.6V power supply
4	P2.2	Digital I/O	
5	P2.1	Digital I/O	
6	P2.0	Digital I/O	
7	P1.7	Digital I/O	
8	P1.6	Digital I/O	
9	GND	GND	Ground
10	GND	GND	Ground
11	SCL	Digital I/O	I2C signal
12	SDA	Digital I/O	I2C signal
13	P1.5	Digital I/O	
14	P1.4	Digital I/O	
15	P1.3	Digital I/O	
16	P1.2	Digital I/O	
17	P1.1	Digital I/O	
18	P1.0	Digital I/O	
19	P0.7	Digital I/O	
20	VDD	Digital POWER	2~3.6V power supply
21	GND	GND	Ground
22	P0.6	Digital I/O	
23	P0.5	Digital I/O	
24	P0.4	Digital I/O	
25	P0.3	Digital I/O	
26	P0.2	Digital I/O	
27	P0.1	Digital I/O	
28	P0.0	Digital I/O	
29	RESET	RESET	Low active
30	GND	GND	Ground

■ Antenna Radiation Pattern

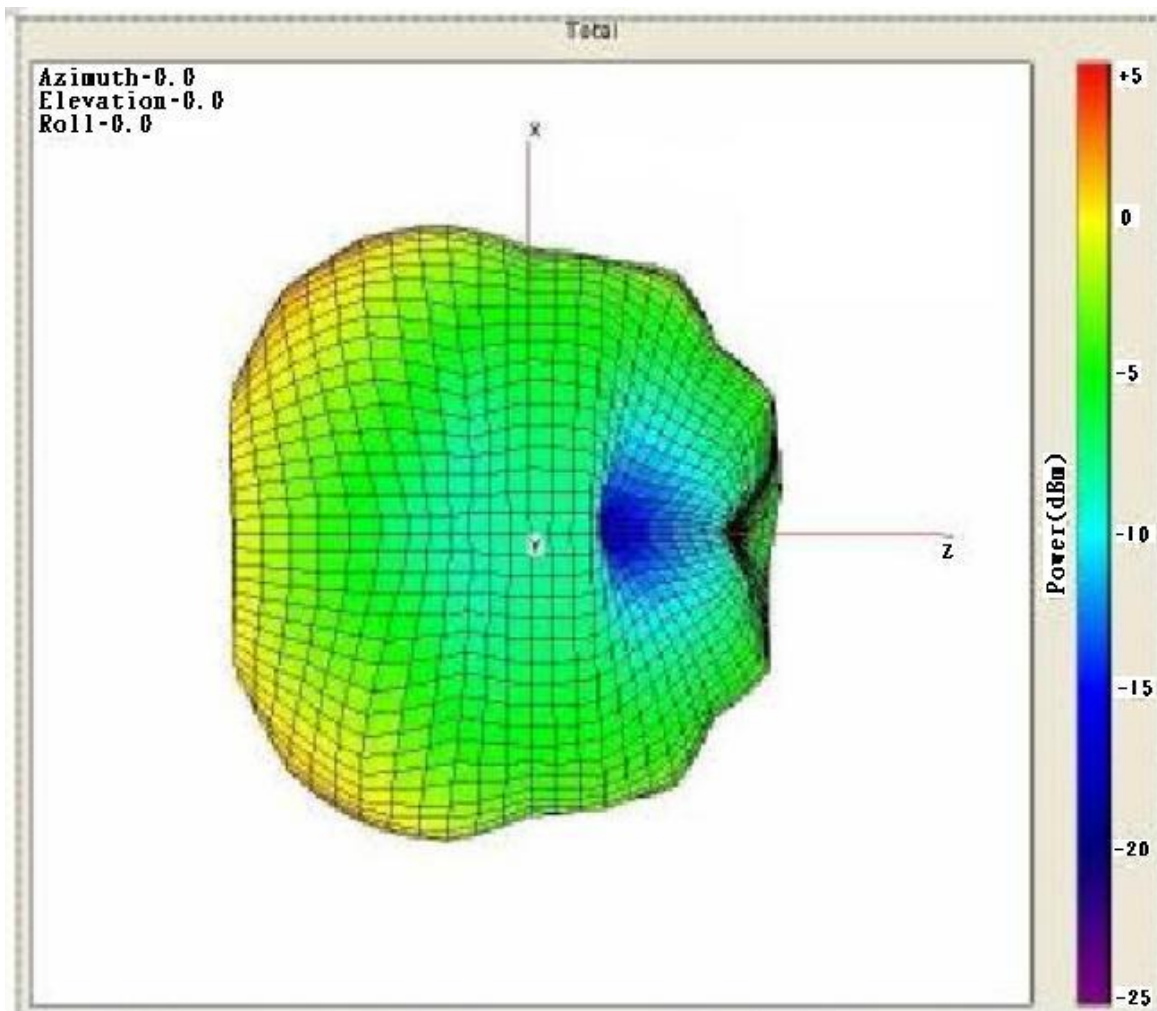
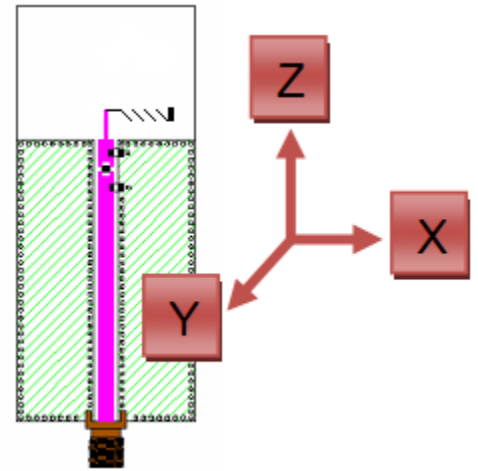

Peak Gain(dBi)	1.44dBi	2.41dBi	1.38dBi
Average Gain(dB)	-3.28dB	-2.65dB	-3.83dB
Efficiency(%)	47.04%	54.31%	41.37%

■ TM41B1412-Fxxx RF Module Example Design schematic

Example schematic:

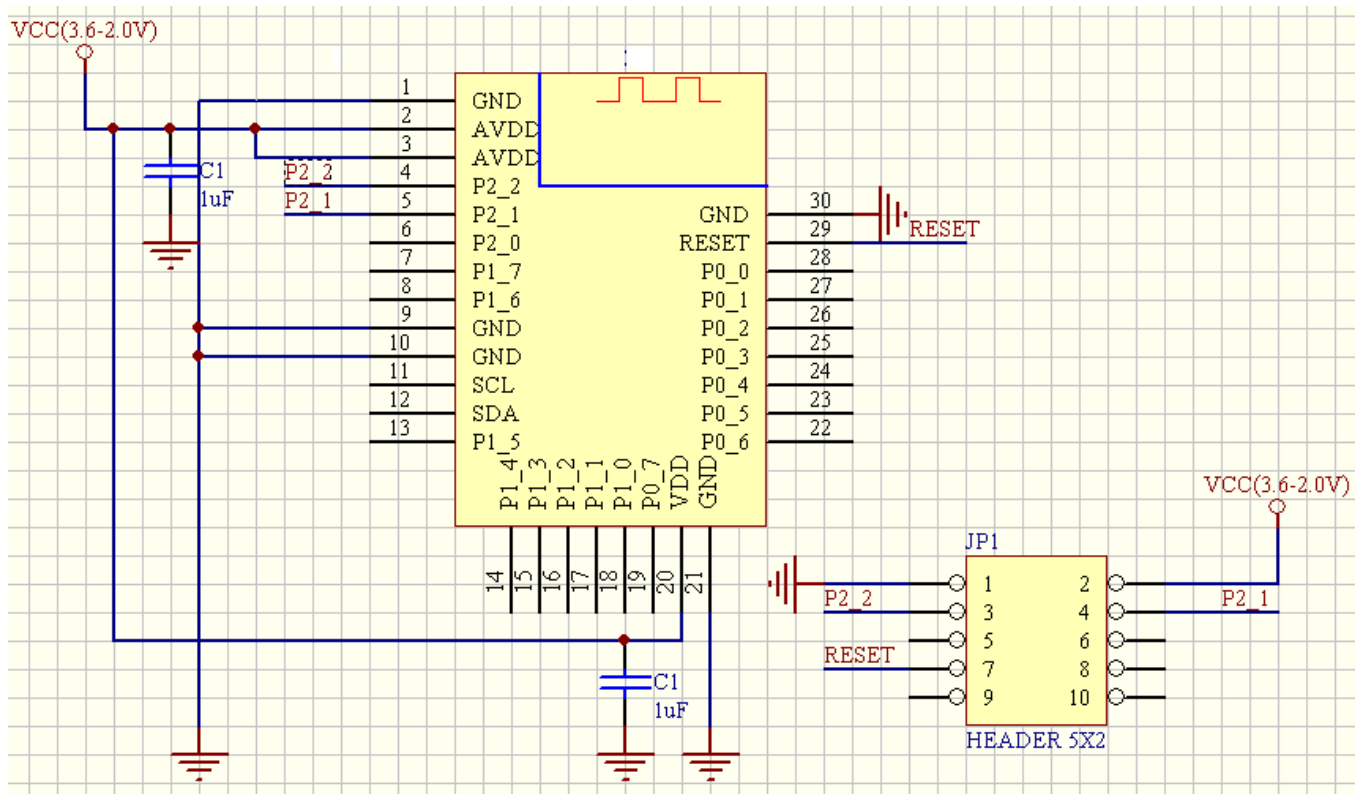

■ TM41B1412-Fxxx RF Module Dimension

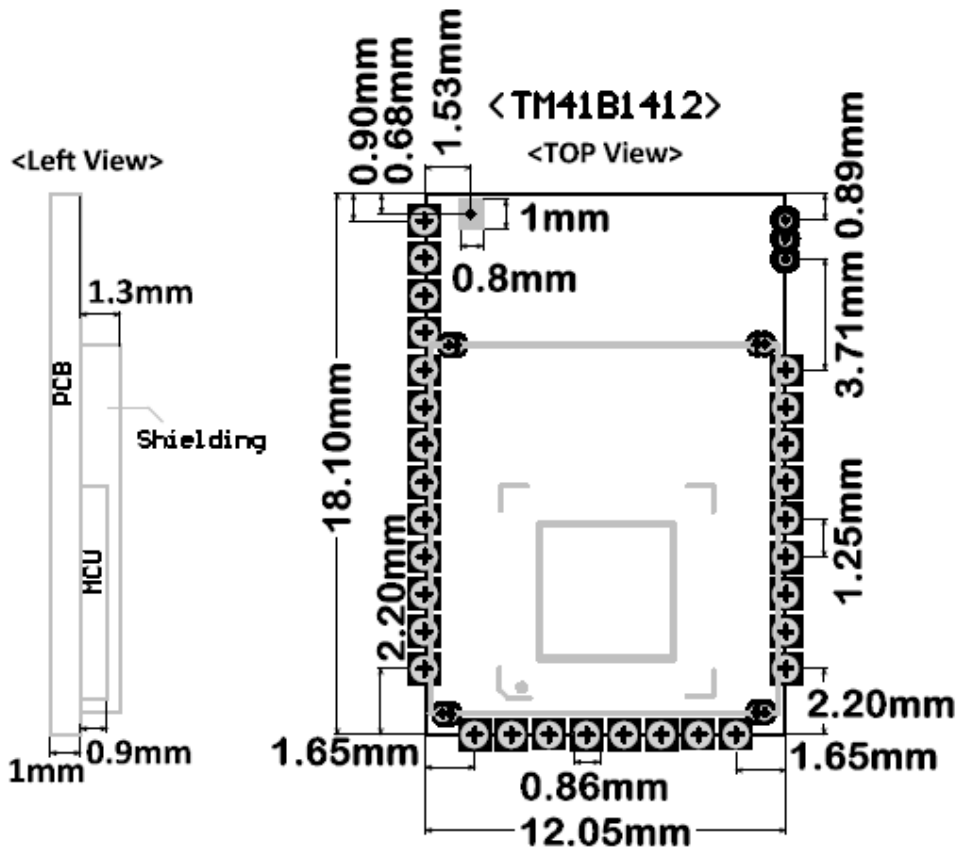

■ Recommended PCB layout for Module

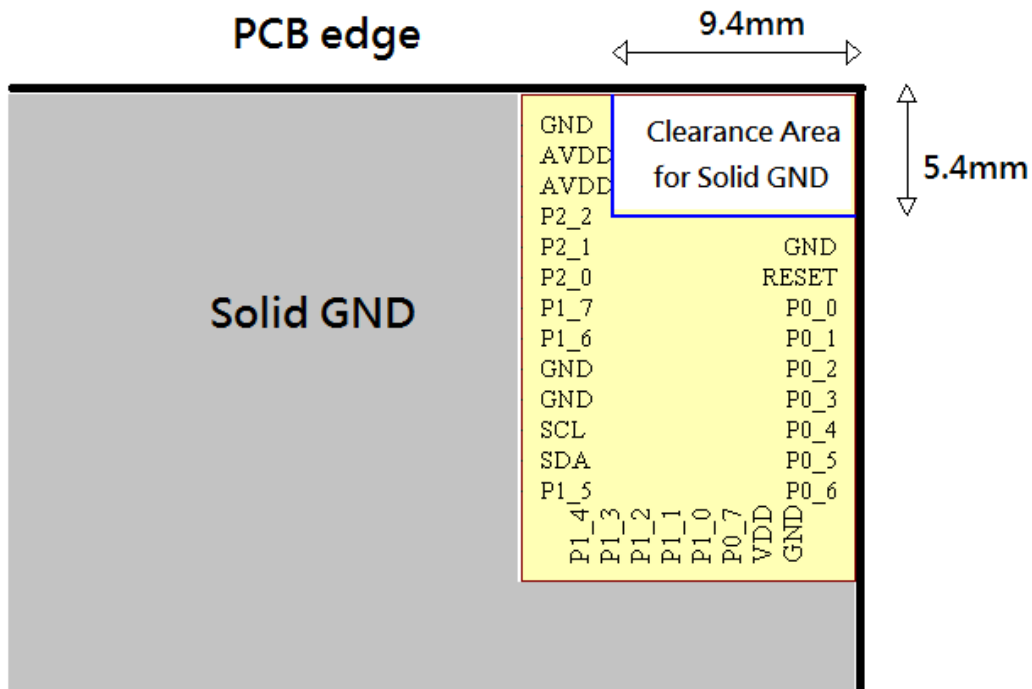
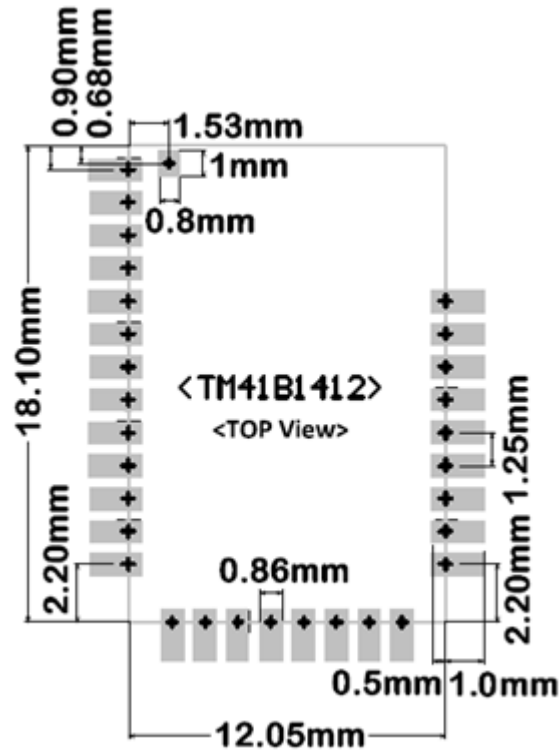

Important FCC notice:

In accordance with FCC Part 15C , this module is listed as a Modular Transmitter device.

Changes or modifications not expressly approved by the manufacturer could void the user's authority to operate the equipment.

The antenna of this transmitter must not be co-located or operating in conjunction with any other antenna or transmitters within a host device, except in accordance with FCC multitransmitter product approval procedures.

FCC Label Instructions

The outside of final products that contains this module device must display a label referring to the enclosed module. This exterior label can use wording such as the

following: **“Contains Transmitter Module FCC ID: 2AEQ4RIFO**

” or **“Contains FCC ID: 2AEQ4RIFO**

.” Any similar wording that expresses the same meaning may be used.

Additionally, there must be the following sentence on the device, unless it is too small to carry it:

“This device complies with part 15 of the FCC Rules. Operation is subject to the following two conditions:

(1) This device may not cause harmful interference, and (2) this device must accept any interference received, including interference that may cause undesired operation.”

FCC Certification only covers the shielded version of the module.

■ Document History

Revision	Date	Description/Changes
1.0	2014.04.08	First release
2.0	2014.12.08	update
3.0	2015.05.05	Update dimension & layout guide for pad of external antenna
3.1	2015.05.19	1. Add module name of external antenna 2.Add Important_FCC_notice & FCC_Label_Instructions
3.2	2015.06.08	Add_TM41B1412-Fxxx & TM41B1412-Exxxx_Picture
3.3	2015.07.23	Page 9: Add FCC Notify.
3.4	2016.04.23	Change layout footprint

■ Address Information

24250 新北市新莊區中山路一段 107 號 13 樓之 1

電話:02-8522-8250

傳真:02-8522-8121

E-mail:rifo@rifo.com.tw

<http://www.rifo.com.tw>



13F.-1, No.107, Sec. 1, Zhongshan Rd., Xinzhuang
Dist., New Taipei City 24250, Taiwan (R.O.C.)

Tel :886-2-8522-8250

Fax:886-2-8522-8121